

## The Mechanism of the Ketene–Imine (Staudinger) Reaction in Its Centennial: Still an Unsolved Problem?

FERNANDO P. COSSÍO\*<sup>†</sup>, ANA ARRIETA<sup>†</sup>, AND MIGUEL A. SIERRA<sup>‡</sup>

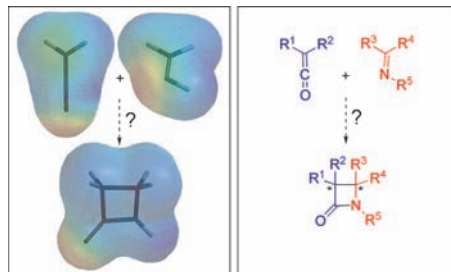
<sup>†</sup>Departamento de Química Orgánica I, Universidad del País Vasco-Euskal Herriko Unibertsitatea. Ap 1072, 20080, San Sebastián-Donostia, Spain,

<sup>‡</sup>Departamento de Química Orgánica, Facultad de Química, Universidad Complutense, 28040-Madrid, Spain

RECEIVED ON FEBRUARY 1, 2008

### CON SPECTUS

Although Staudinger reported the reaction between ketenes and imines 100 years ago (1907), this process is still the most general and useful method for the synthesis of  $\beta$ -lactams and their derivatives. This reaction is a [2 + 2] thermal cycloaddition in which two chiral centers may be generated in one preparative step. Staudinger reactions involving  $\alpha,\beta$ -unsaturated imines or ketenes have issues concerning the [2 + 2] or [4 + 2] periselectivity of the reaction. This Account discusses how the main factors that determine the regiochemical and stereochemical outcomes of this reaction were elucidated with computational and experimental data. This fruitful interplay between theory and experiment has revealed that the [2 + 2] cycloaddition is actually a two-step process. The first step is a nucleophilic addition of the nitrogen atom of the imine on the *sp*-hybridized carbon atom of the ketene. This attack forms a zwitterionic intermediate that evolves toward the final  $\beta$ -lactam cycloadduct. The second step can be viewed as a four-electron conrotatory electrocyclicization that is subject to torquoelectronic effects. When  $\alpha,\beta$ -unsaturated imines are used, the zwitterionic intermediates yield either the corresponding 4-vinyl- $\beta$ -lactams or the alternative 3,4-dihydropyridin-2(1*H*)-ones. In this latter case, the cyclization step consists of a thermal disrotatory electrocyclicization. In the context of stereoselectivity, it is usually assumed that the first step takes place through the less hindered side of the ketene. The *cis*–*trans* selectivity of the reaction depends on the geometry of the imine. As the general rule, (*E*)-imines form *cis*- $\beta$ -lactams whereas (*Z*)-imines yield *trans*- $\beta$ -lactams. Most of the experimental results point to the two-step model. The asymmetric torquoselectivity of the conrotatory ring closure of the second step accounts for the stereochemical discrimination in the reaction of chiral ketenes or chiral imines. Nevertheless, recent studies have revealed that isomerization paths in the imine or in the zwitterion may determine the stereochemistry of the reaction. Thus, if the rotation about the N1–C4 bond of the zwitterion intermediate is faster than the cyclization, the formation of *trans*- $\beta$ -lactams from (*E*)-imines is biased. Alternatively, in some cases, the (*E*)–(*Z*) isomerization of the starting imines prior to the cycloaddition steps also results in the formation of *trans*-cycloadducts. Although the main variables that govern the outcome of the reaction have been elucidated, there are still several aspects of the reaction yet to be disclosed. Finally, the discovery of the catalytic version of the reaction is a new and formidable mechanistic challenge and will be a nice playground for forthcoming theoretical–experimental discussions.



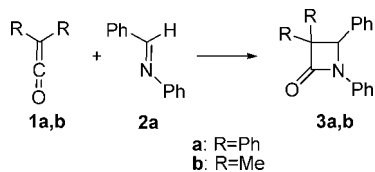
### 1. Introduction

Staudinger reported in 1907 the reaction of diphenylketene (**1a**) or dimethylketene (**1b**) and *N*-phenyl benzylideneamine (**2a**) yielding 1,3,3,4-tetraphenylazetid-2-one (**3a**) and 3,3-dimethyl-1,4-diphenylazetid-2-one (**3b**), respectively.<sup>1</sup> After 100 years,<sup>2</sup>

this general reaction yielding  $\beta$ -lactams is the method of choice for the synthesis of these strained heterocycles.<sup>3</sup> The relevance of this venerable centenary reaction has steadily increased during the years. Today the azetid-2-ones ( $\beta$ -lactams) maintain their fundamental role as antibacterial agents in

medicinal chemistry,<sup>4</sup> and they are widely used as key synthetic intermediates.<sup>5</sup>

**SCHEME 1.** The Reactions between Ketenes **1a,b** and *N*-Phenyl Benzylideneamine, **2a**, as Reported by Staudinger in 1907



The reaction written in Scheme 1 is straightforward from a synthetic point of view. However, few other reactions have raised such longstanding debate about their mechanisms. The interest in these apparently simple processes may be due to the following features:

- The concerted or stepwise nature of the cycloaddition.
- Two stereogenic centers may be formed during the cycloaddition reaction whose formation can be effected with complete stereocontrol.<sup>6</sup>
- For  $\alpha,\beta$ -unsaturated imines<sup>7</sup> or ketenes,<sup>8</sup> the formation of unsaturated  $\delta$ -lactams is also conceivable, a fact that poses novel stereoselectivity and periselectivity issues.
- The catalytic Staudinger reaction<sup>9</sup> between ketenes and imines has opened novel methodologies for the synthesis of enantiopure  $\beta$ -lactams and derivatives using homochiral organometallic<sup>10</sup> and organic catalysts, posing novel mechanistic clues.<sup>11</sup>

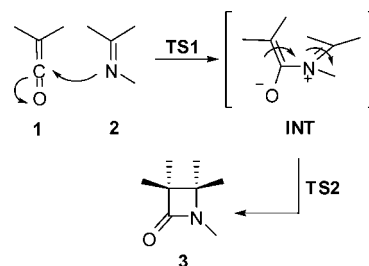
The complexity of these processes was exposed by the pioneering work of Cooper et al.<sup>12</sup> In this Account, we discuss the main features, unsolved aspects, and challenges posed by this fascinating reaction in its centennial.

## 2. Mechanism of the Reaction between Imines and Ketenes: Concerted or Stepwise?

The formation of a  $\beta$ -lactam from the interaction between a ketene and an imine is, formally, a [2 + 2] cycloaddition. The Woodward and Hoffmann<sup>13</sup> rules allow these thermal cycloadditions provided that the reactions follow a [ $\pi 2s + \pi 2a$ ] approach. The low steric congestion of the sp-hybridized carbon atom of the ketene makes this sterically demanding mechanism possible. Additionally, [ $\pi 2s + (\pi 2s + \pi 2s)$ ] mechanisms can be proposed for this reaction, in a way similar to that suggested by Zimmerman<sup>14</sup> for the reaction between ketenes and alkenes to form cyclobutanones. Over the years, several computational studies on model systems in the gas phase have pointed to these concerted mechanisms.<sup>15</sup>

The simplest situation depicted above complicates when the mechanisms of these reactions are studied in solution. Overwhelming experimental<sup>3,6,7</sup> (vide infra) and computational<sup>16,17</sup> evidence indicates that the mechanism in solution<sup>18</sup> of the Staudinger reaction between ketenes and imines is not concerted but stepwise. The accepted current mechanism for these reactions in solution involves the initial nucleophilic addition of the imine nitrogen atom to the central carbon atom of the ketene to form a zwitterionic intermediate (Scheme 2).

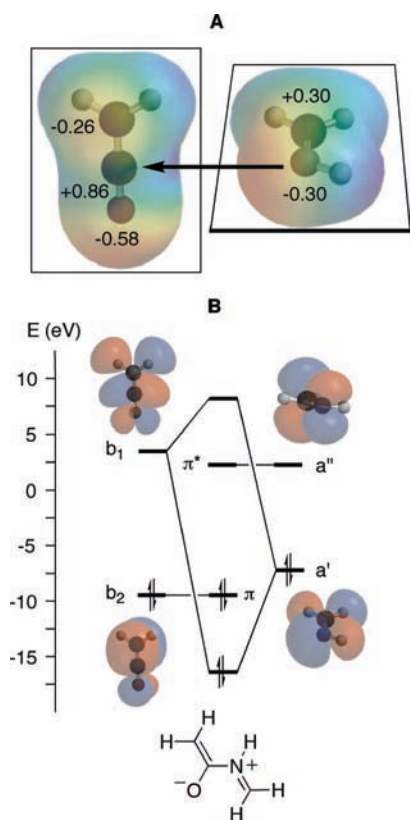
**SCHEME 2.** The Stepwise Mechanism of the Staudinger Reaction between Ketenes **1** and Imines **2**



Electrostatic interactions and the transfer of electron density from the ketene **1** to the imine **2** (Figure 1A), forming an acyclic intermediate with a new C–N  $\sigma$  bond, favor this attack (Figure 1B). Therefore, this step is not symmetry-restricted and the C1–N2–C3–C4 dihedral angle can adopt any value.

The isolation of these zwitterionic intermediates or their detection has been a widely pursued goal. Kagan<sup>19a</sup> and Bellus<sup>19b</sup> reported the formation of *trans*-thiazolidin-4-one 1,1-dioxides **4** by reaction between ketenes **1c** and imines **2a** in the presence of liquid SO<sub>2</sub>. Formation of cycloadducts **4** was postulated to occur by cheletropic reaction of SO<sub>2</sub> on the zwitterionic intermediates **INTa** (Scheme 3a). Moore<sup>7b</sup> reported the formation of amides **5** by the reaction of ethanol with intermediates **INTb** arising from the reaction between chlorocyanoketene **1d** and imidate **2b** (Scheme 3b). We observed<sup>20</sup> the formation of  $\delta$ -lactams **6** in the reaction between ketene **1e** and imine **2c**. Since [2 + 2 + 2] reactions are very improbable in the absence of suitable catalysts, we attributed the formation of these cycloadducts to the [4 + 2] cycloaddition between a second equivalent of imine **2c** and the **INTc** (Scheme 3c).

Pacansky<sup>21</sup> and Wentrup<sup>22</sup> reported the formation of zwitterions **INTd,e** from the reaction between stabilized ketenes **1fg** and imidazoles **7** or pyridine, respectively (Scheme 4a,b). In these cases, the aromaticity of the heterocycles precluded the evolution of these zwitterions to the  $\beta$ -lactam products. However, when electron-withdrawing groups are present in the imidazole ring, new IR bands observed at 1770 cm<sup>-1</sup> were attributed<sup>21</sup> to the formation of  $\beta$ -lactams **3c** (Scheme



**FIGURE 1.** The first step of the Staudinger reaction: (A) electrostatic potential projected onto electron density (red,  $-50$  kcal/mol; blue,  $+37$  kcal/mol) and charges of ketene and formalimine (in atomic units, including those of the hydrogens attached to the heavy atoms); (B) orbital interaction diagram associated with the formation of the C–N bond. The depicted MOs correspond to the canonical orbitals computed at the HF/6-31G\* level of theory.

4a). Pannunzio<sup>23</sup> reported the unambiguous formation of intermediates **INTf** in the reaction between ketenes of type **1h** and *N*-silylimines **2d** (Scheme 4c). These intermediates were completely characterized and transformed into the corresponding *N*-silyl- $\beta$ -lactams **3d**.

The zwitterionic intermediates **INTd** and **INTf** depicted in Scheme 4 formed the corresponding  $\beta$ -lactams **3c,d**. The formation of the  $\beta$ -lactam ring should take place via conrotatory electrocyclization of the zwitterionic intermediate (Scheme 5). However, the extension of the classical Woodward–Hoffmann [ $\pi$ 4c] mechanism to the second step of the Staudinger reaction is not direct,<sup>24</sup> since the frontier molecular orbitals (FMOs) of the intermediates **INT** are different in nature from the ones of 1,3-butadiene. The FMOs of the zwitterionic intermediates derived from the initial attack of the imine lone pair to the ketene are the unperturbed highest occupied molecular orbital (HOMO) of the ketene and lowest unoccupied molecular orbital (LUMO) of the imine ( $\pi$  and  $\pi^*$ , respectively, Figure 1B). Therefore, the second step of the Staudinger reaction can also be viewed as an intramolecular

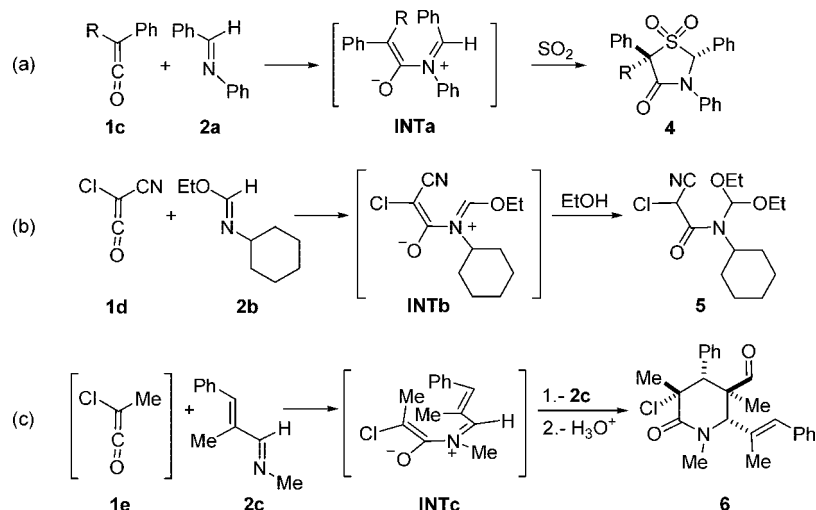
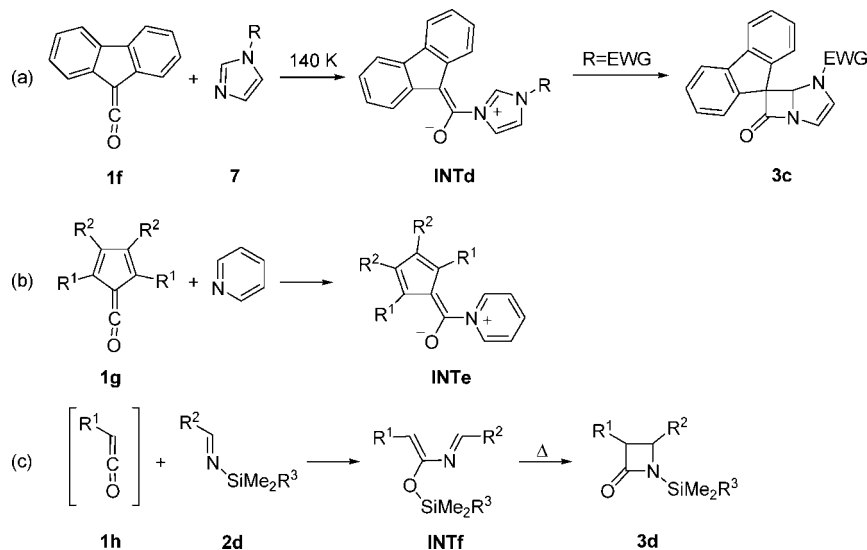
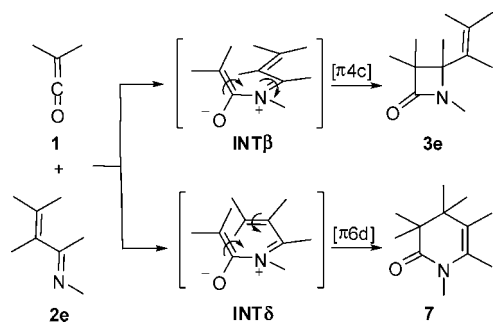
Mannich-like reaction, in which the  $\pi$  MO (similar to the HOMO of an enolate) experiences nucleophilic addition on the  $\pi^*$  LUMO, analogous to the LUMO of an imine or iminium cation.<sup>16,24</sup> However, this intramolecular nucleophilic addition is facilitated by an in-phase coupling between the  $\pi$  and  $\pi^*$  FMOs (Figure 2A), leading to a topology between the terminal atoms similar to that found in the HOMO of butadiene. This results in a conrotatory motion to form the new  $\sigma$  C3–C4 bond, denoted in purple in Figure 2. The  $\pi$ – $\pi^*$  mixing can be observed in the canonical LUMO corresponding to **TS2a** (Figure 2B).

The strong analogy observed in the torquoselectivity of these reactions compared with the conrotatory electrocyclic reactions of butadienes further supports the pericyclic reactivity of the zwitterions formed in the Staudinger reaction. Houk coined the term torquoselectivity to define the stereoelectronic effects associated with the torsion of a  $\pi$ -system to form a cycle.<sup>25</sup> The positions of the substituents at the terminal carbon atoms in conrotatory electrocyclizations are not equivalent in the corresponding transition structures, with electron-donating groups having a strong bias for the outward positions and electron-withdrawing groups preferring the inward positions.<sup>26</sup> The analysis of the relative energies of the transition structures having inward and outward substituents [ $\Delta\Delta E_{\text{in-out}} = \Delta E_{\text{a}}(\text{TS}_{\text{inward}}) - \Delta E_{\text{a}}(\text{TS}_{\text{outward}})$ ] shows a linear correlation between the transition structures corresponding to the electrocyclization of 1,3-butadienes<sup>27</sup> and the analogous zwitterionic intermediates of the Staudinger reaction<sup>28</sup> (Figure 3). The slope of the linear regression is close to 1.0, thus indicating that the torquoelectronic effects operating in both reactions are very similar in magnitude.

### 3. Periselectivity

The reaction of ketenes and  $\alpha,\beta$ -unsaturated imines can yield either  $\beta$ - or  $\delta$ -lactams (Scheme 5). This fact introduces the question of [2 + 2] vs [4 + 2] periselectivity. Now, conrotatory electrocyclization of intermediates **INT $\beta$**  leads to 4-vinyl- $\beta$ -lactams **3e**, whereas disrotatory ring closure of the **INT $\delta$**  conformers yields the corresponding  $\delta$ -lactams **7**.<sup>7,20</sup>

The analysis of the FMOs of both intermediates leads to the diagrams shown in Figure 4. For **INT $\beta$** , the termini at C3 and C4 (highlighted in purple) require a conrotatory motion to form the  $\beta$ -lactam cycloadducts **3e**. The in-phase coupling of  $\pi$  and  $\pi^*$  in **INT $\delta$**  requires disrotatory electrocyclization to yield the six-membered cycloadduct **7**. These  $\pi$ – $\pi^*$  interactions are also found in the HOMO of the transition structure associated with formation of  $\delta$ -lactams **7** (Figures 4 and 5).

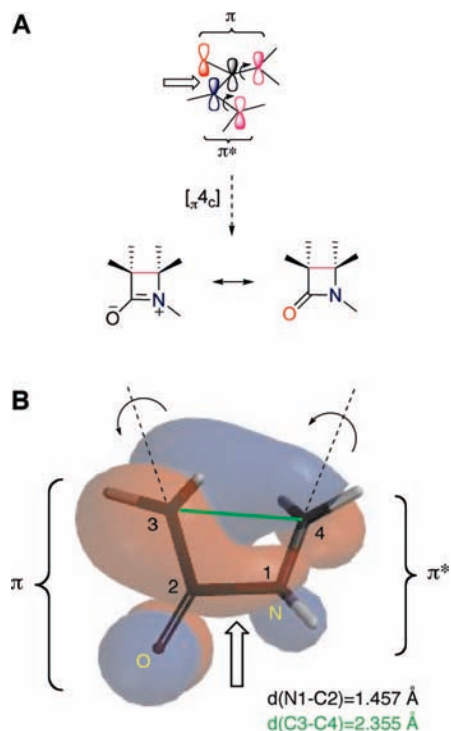
**SCHEME 3.** Trapping Experiments in the Interaction between Ketenes and Molecules Containing C=N Bonds

**SCHEME 4.** Direct Detection of the Intermediate Zwitterions in the Interaction between Ketenes and Molecules Containing C=N Bonds

**SCHEME 5.** Reaction between Ketenes and  $\alpha,\beta$ -Unsaturated Imines **2e** To Yield  $\beta$ -Lactams **3e** or  $\delta$ -Lactams **7**


Zwitterions **INT $\beta$**  and **INT $\delta$**  derived from ketene **1** and imines **2e** (Scheme 5) may equilibrate via rotation about the C4–C bond.<sup>29</sup> Therefore, the relative energies of the conrotatory or disrotatory transition structures determine

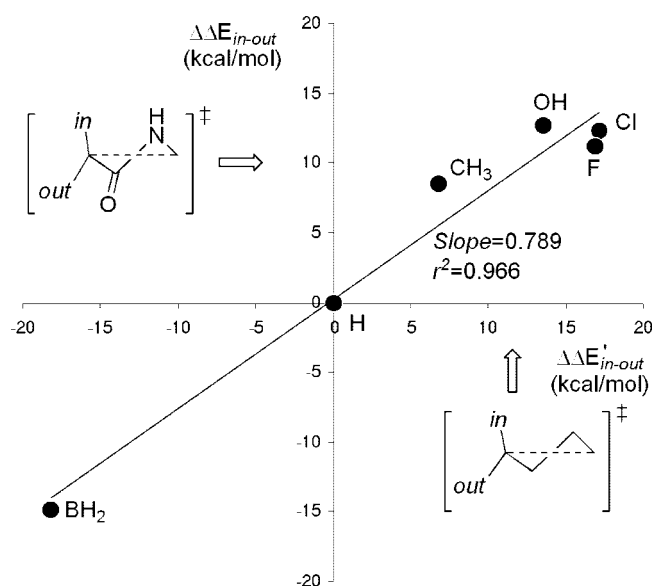
the periselectivity ( $[4 + 2]$  vs  $[2 + 2]$  cyclization) of the reaction. Figure 5 shows the general shapes of both transition structures. It is clear that the steric interaction between the  $\text{R}^2$  and  $\text{R}^3$  groups in the disrotatory transition structure (Figure 5B) is stronger than that in the conrotatory transition structure (Figure 5A). Therefore, preferential or exclusive formation of  $[2 + 2]$  cycloadducts is expected, especially when both  $\text{R}^2$  and  $\text{R}^3$  are bulky substituents. This fact has been demonstrated experimentally in the reaction between chloroketenes **1d** and **1i** and imines **2f,g**<sup>7a</sup> and **2h,i**<sup>7b</sup> (Scheme 6). For  $\text{R} = \text{H}$ , only  $[2 + 4]$  cycloadducts are obtained, whereas for  $\text{R} = \text{Ph}$  (imines **2h,f**,  $\text{R} = \text{Ph}$ ), only the  $[2 + 2]$  cycloadducts are obtained.

The alternate situation, namely, the reaction between vinylketenes and imines may form either 3-vinyl- $\beta$ -lactams or



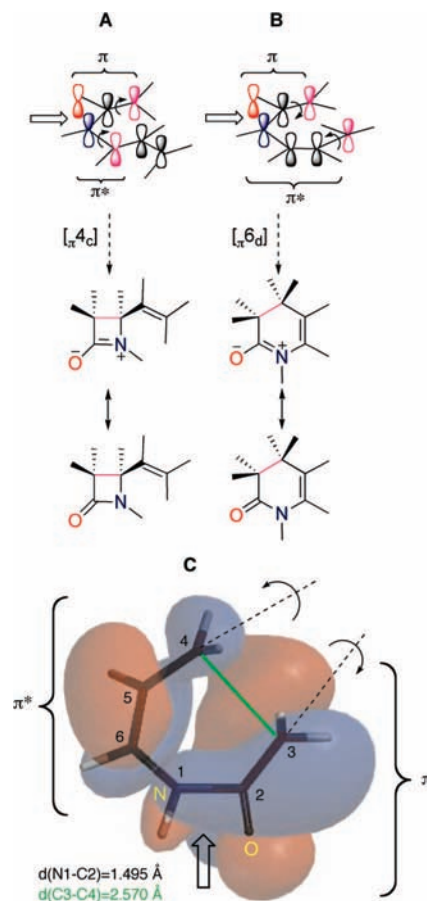


**FIGURE 2.** (A) Orbital topology associated with the conrotatory electrocyclicization leading to  $\beta$ -lactams. The hollow arrows emphasize the in-phase coupling between the  $\pi$  and  $\pi^*$  FMOs of the zwitterionic intermediates shown in Figure 1. (B) Main geometric features and shape of the HOMO of the second step of the formation of  $\beta$ -lactams.

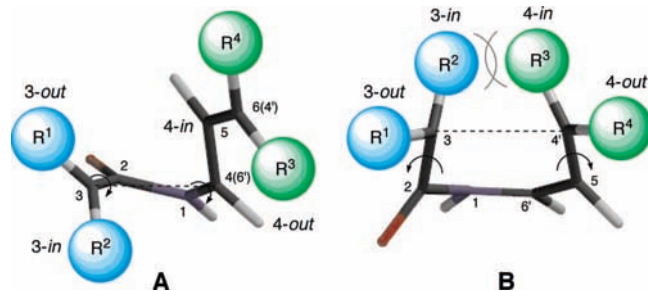


**FIGURE 3.** Differences in computed activation energies between 3-in and 3-out transition structures in the second step of Staudinger reaction between monosubstituted ketenes and formaldimine ( $\Delta\Delta E_{in-out}$ ) and in the conrotatory electrocyclic reaction of 3-substituted cyclobutenes ( $\Delta\Delta E_{in-out}$ ).

5,6-dihydropyridin-2(1*H*)-ones. Experimental results indicate that both vinylketene<sup>30a</sup> **1j** and methylvinylketene<sup>30b</sup> **1k** yield the corresponding [2 + 2] cycloadducts **3h–j** exclusively.

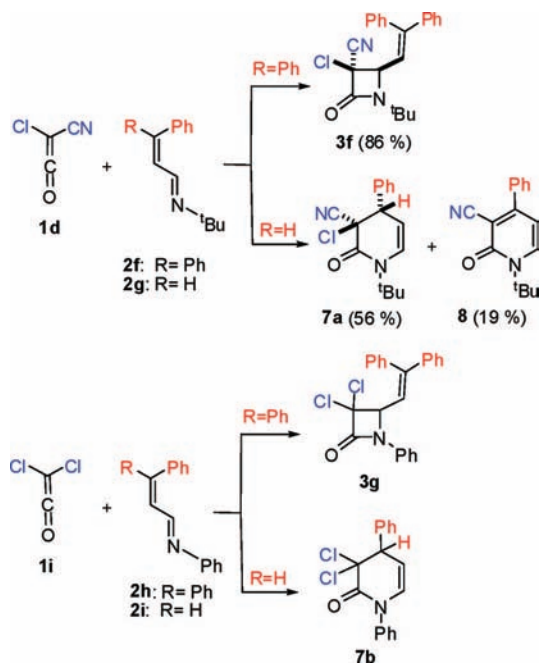
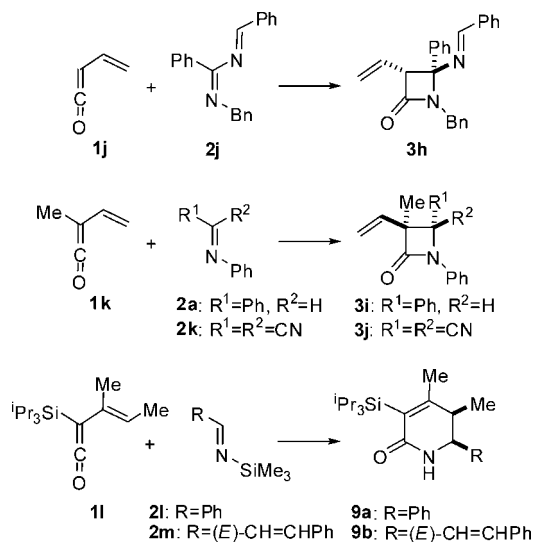


**FIGURE 4.** Orbital topologies associated with the second step of the ketene– $\alpha,\beta$ -unsaturated imine reaction: (A) conrotatory electrocyclicization leading to 4-vinyl- $\beta$ -lactams; (B) disrotatory electrocyclicization leading to  $\gamma,\delta$ -unsaturated- $\delta$ -lactams; (C) main geometric features and shape of the HOMO of the second step of the Staudinger reaction leading to the formation of  $\delta$ -lactams. The hollow arrows emphasize the in-phase coupling between the  $\pi$  and  $\pi^*$  FMOs of the corresponding zwitterionic intermediates as shown in Figure 1.



**FIGURE 5.** General shape of the conrotatory (A) and disrotatory (B) transition structures for the second step of the reaction between ketenes and  $\alpha,\beta$ -unsaturated imines to yield  $\beta$ - and  $\delta$ -lactams, respectively.

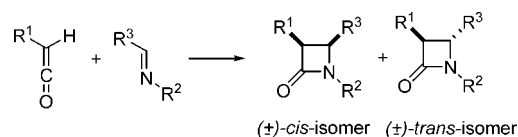
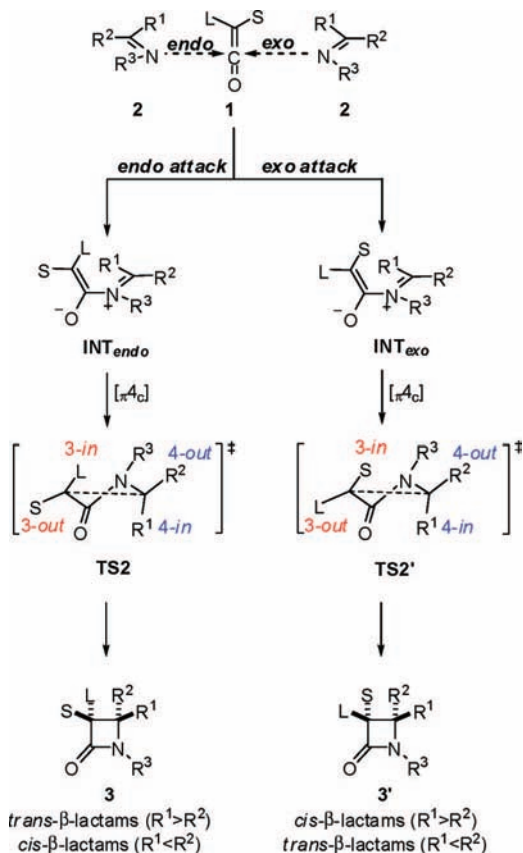
Bulkier silylvinylketenes like **1p** form exclusively the corresponding [4 + 2] cycloadducts<sup>B</sup> (Scheme 7). This latter reaction has not been studied computationally.

**SCHEME 6.** Examples of the Periselectivity of the Staudinger Reaction between Ketenes and  $\alpha,\beta$ -Unsaturated Imines**SCHEME 7.** Examples of the Periselectivity of the Staudinger Reaction between Vinylketenes and Imines

#### 4. Cis–Trans Selectivity

The reaction of unsymmetrically substituted ketenes or imines may form *cis*- and *trans*- $\beta$ -lactams (Scheme 8).

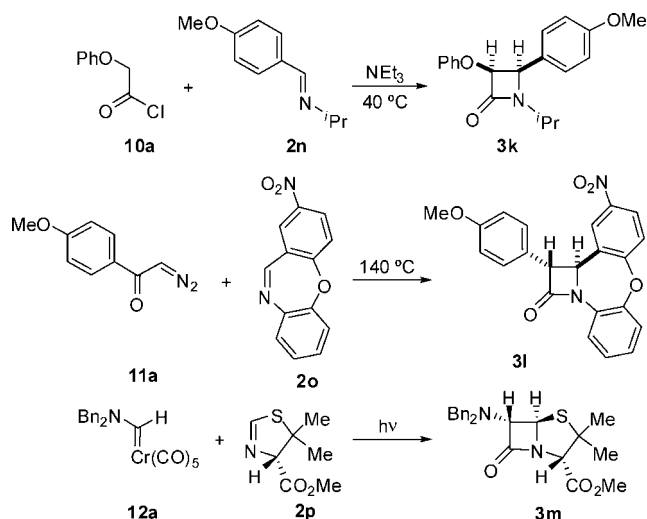
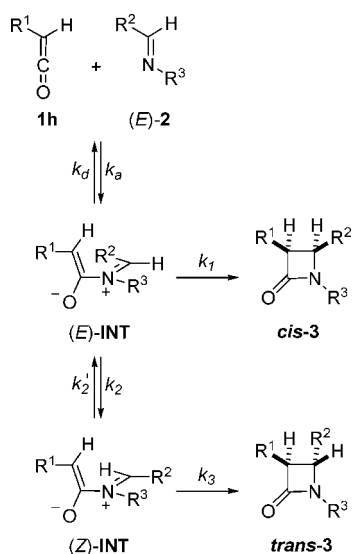
The stepwise model for the Staudinger reaction allows the imine nitrogen of **2** to interact with the LUMO of ketene **1** either via the less hindered side of this reagent to yield intermediates  $\text{INT}_{\text{exo}}$  (*exo* attack, Scheme 9) or by the opposite side of the ketene (*endo* attack,  $\text{INT}_{\text{endo}}$ ). Steric considerations lead to the expectation of the preferential formation of *exo* intermediates  $\text{INT}_{\text{exo}}$ . It is noteworthy that the *exo* attack in the first

**SCHEME 8.** Formation of *cis*- and *trans*- $\beta$ -Lactams from the Staudinger Reaction between Monosubstituted Ketenes and Aldimines**SCHEME 9.** General Stereochemistry of the Staudinger Reaction<sup>a</sup>

<sup>a</sup> S and L stand for small and large substituents, respectively.

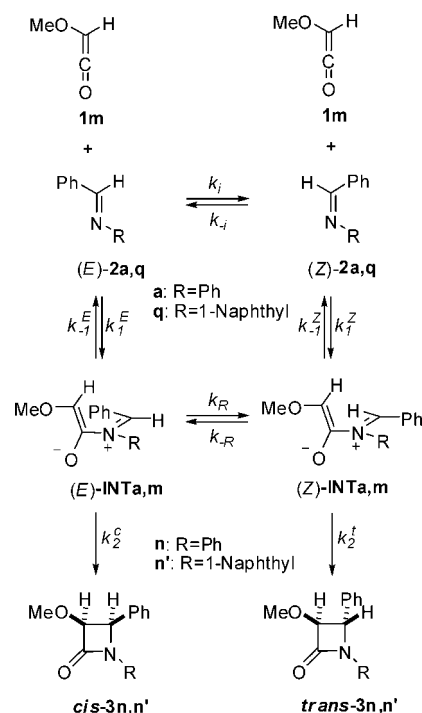
step of the Staudinger reaction forms transition structures  $\text{TS2}'$  having the largest substituent of the ketene at the 3-out position. The torquoelectronic model predicts preferential 3-out transition structures when  $\pi$ -donors are present (vide supra). Therefore, the preferential *exo* attack in the first step of the reaction results in lower energy conrotatory transition structures.<sup>16</sup> This fact leads to *cis*- $\beta$ -lactam from (*E*)-imines and to *trans*- $\beta$ -lactams from (*Z*)-imines. Thence, cyclic imines having a fixed *Z*-configuration react with ketenes yielding *trans*- $\beta$ -lactams, while acyclic imines (*E*-isomers) should form preferentially or exclusively *cis*- $\beta$ -lactams (Scheme 9).<sup>31</sup>

In many cases, the experimental results nicely agree with the model. Thus, cyclic imines,<sup>31,32</sup> like **2o,p** result in the exclusive formation of *trans*- $\beta$ -lactams, whereas acyclic imi-

**SCHEME 10.** Examples of the Formation of *cis*- and *trans*- $\beta$ -Lactams from Acyclic and Cyclic Imines**SCHEME 11.** Formation of *cis*- and *trans*- $\beta$ -Lactams via *exo* Attacks of (*E*)-Imines, According to the Kinetic Scheme Proposed by Xu et al

nes like **2n** yield the *cis* cycloadducts as major isomers<sup>24b</sup> (Scheme 10).

However, an alternative explanation would be competing isomerization paths between the intermediate zwitterions (*E*)-**INT** and (*Z*)-**INT** (Scheme 11). This possibility was suggested for the Staudinger reaction involving imidates (ROCH=NR'), in which always the corresponding *trans*-4-alkoxy- $\beta$ -lactams are obtained.<sup>33</sup> Xu et al. explored this isomerization in a series of outstanding studies.<sup>24,32</sup> According to these authors assuming an *exo* attack in the first step of the reaction, the zwitterionic intermediate (*E*)-**INT** can evolve in two ways: it can cyclize to form the corresponding *cis*- $\beta$ -lactam, or it can isomerize via rotation about the N1–C4 bond to form the cor-

**SCHEME 12.** Kinetic Scheme for the Formation of *cis*- and *trans*- $\beta$ -Lactams in the Reaction of Methoxyketene and *N*-Arylimines<sup>a</sup>

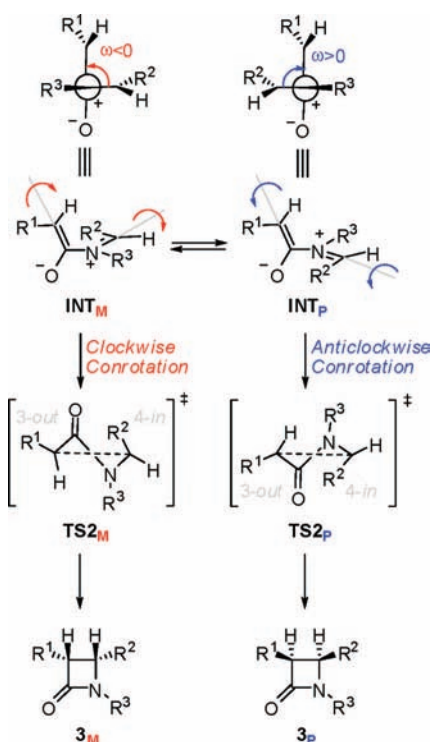
<sup>a</sup> *Exo*-attacks followed by isomerization of the zwitterionic intermediates or the starting imines are considered.

responding intermediate (*Z*)-**INT**, which irreversibly cyclizes to the *trans*-cycloadduct (Scheme 11).

Banik<sup>34</sup> reported that methoxyketene derived from methoxyacetyl chloride reacts with imine **2a** to form the *cis*- $\beta$ -lactam **3n**, while imine **2q** forms exclusively the cycloadduct *trans*-**3n**. These experimental results pointed to the more complex kinetic scheme depicted in Scheme 12, which has been thoroughly examined by us and Banik to explain this stereodivergent behavior.<sup>35</sup> B3LYP/6-31G\* simulations (including solvent effects) indicated that when the substituent in the imine nitrogen is Ph, the nucleophilic attack on the ketene is faster than the *E/Z*-isomerization of the imine, thus yielding the *cis*- $\beta$ -lactam **3n**. When this substituent is 1-naphthyl, the isomerization is faster than the nucleophilic attack and only *trans*-**3n** is obtained. Therefore, the stereochemical outcome of the Staudinger reaction in some cases is also dependent on the isomerization of the imine prior the cycloaddition stages.<sup>36</sup>

## 5. The Enantioselectivity Question

Scheme 13 depicts both possible intermediates leading to enantiomeric *cis*-2-azetidinones. In the absence of chiral substituents either at the ketene or at the imine, the intermediates **INT** are enantiomeric pairs of conformers, which may

**SCHEME 13.** Formation of Chiral  $\beta$ -Lactams via Clockwise or Anticlockwise Conrotations<sup>a</sup>


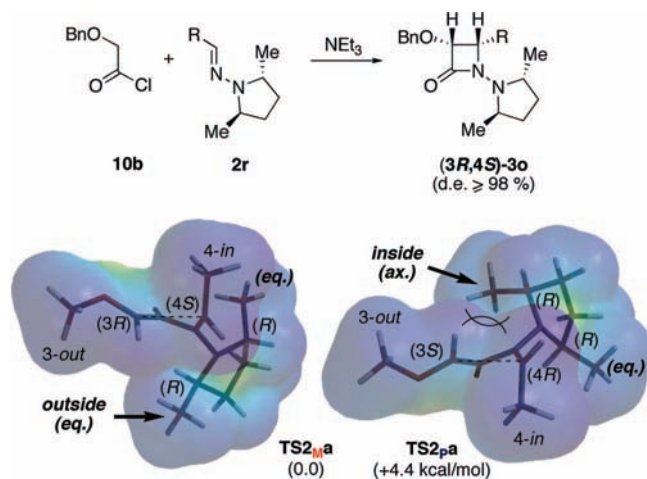
<sup>a</sup>  $\omega$  denotes the dihedral angle C4–N1–C2–C3 of the  $\beta$ -lactam ring to be formed.

interconvert via rotation about the N1–C2 bond. If the dihedral angle  $\omega = \text{C4–N1–C2–C3}$  is negative, the formation of  $\beta$ -lactam  $3_M$  takes place via clockwise conrotation about the C4–N1 and C2–C3 bonds in concert with rotation about the N1–C2 bond ( $\omega \rightarrow 0$ ). Similarly, anticlockwise conrotation of  $INT_P$  leads to the enantiomer  $3_P$ .

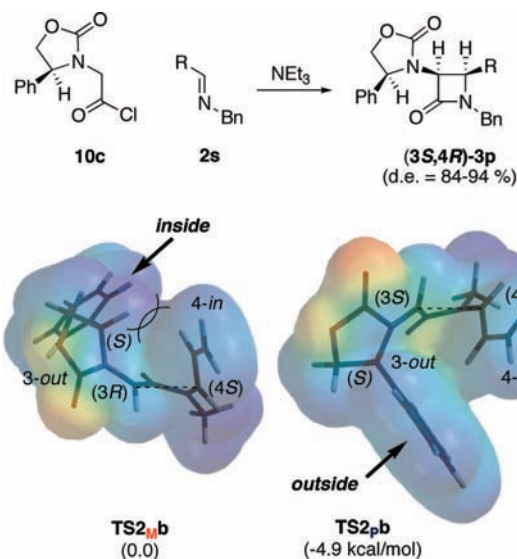
When substituents  $R^1$ ,  $R^2$ , and  $R^3$  are achiral, both transition structures  $TS2_M$  and  $TS2_P$  (Scheme 12) are isoenergetic and a racemic pair of  $3_M$  and  $3_P$  is obtained. However, should any substituent  $R^1$ – $R^3$  be chiral and its effect on the relative energies of  $TS2_M$  and  $TS2_P$  proved to be large enough, the predominant or exclusive formation of one of the possible *cis*-stereoisomers will be expected. Enantiomerically (with respect to the four-membered ring) enriched or pure 2-azetidinones have been obtained by placing chiral auxiliaries in all the available positions of the imine and the ketene.

### 5.1. Imines Having Chiral Auxiliaries at the Nitrogen.

Simple  $C_2$ -symmetric chiral groups incorporated at the N1-position of the emerging  $\beta$ -lactam ring produced excellent diastereoselectivities,<sup>37</sup> while other chiral substituents at the imine nitrogen usually produce fair selectivities. The nearly complete diastereoselectivities observed in the reaction of ketenes derived from acid chloride **10b** with hydrazones **2r** to yield (3*R*,4*S*)- $\beta$ -lactams **3o** (Figure 6) have been studied at the



**FIGURE 6.** A selected example of high diastereoselection induced from the N1 position of the  $\beta$ -lactam to be formed. Geometries and relative energies were calculated by Fernández, Lassaletta et al.<sup>37</sup> at the B3LYP/6-31G\* level.

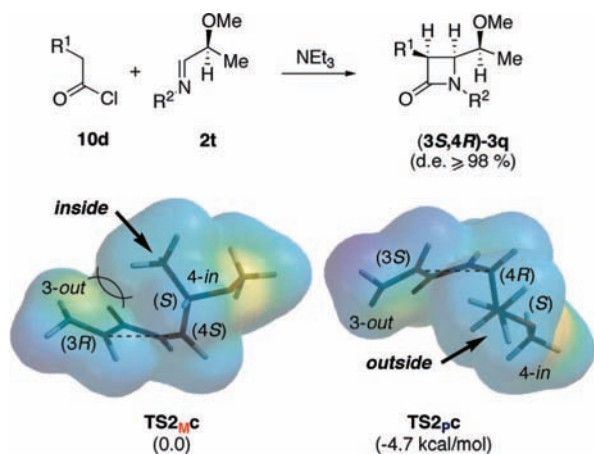


**FIGURE 7.** A selected example of high diastereoselection induced from the C3 position of the  $\beta$ -lactam to be formed: RHF/AM1 geometries and relative enthalpies for saddle points  $TS2_{Mb}$  and  $TS2_{Pb}$ .

B3LYP/6-31G\* level showing that the origin of this selection is the unfavorable inside axial disposition of one of the pyrrolidine's Me-groups in  $TS2_{Pa}$ , which is not present in  $TS2_{Ma}$ .

**5.2. Chiral Ketenes.** Evans and Sjogren<sup>38</sup> showed that ketenes derived from chiral 2-((*S*)-2-oxo-4-phenyloxazolidin-3-yl)acetyl chloride **10c** can react with imines to yield *cis*- $\beta$ -lactam (3*S*,4*R*)-**3p** with excellent diastereocontrol. The origin of this stereocontrol stems from the orientation of both C=O dipoles in transition structures  $TS2_{Mb}$  and  $TS2_{Pb}$  (Figure 7).<sup>39</sup> The lowest energy saddle point has the phenyl group outside the emerging  $\beta$ -lactam ring, whereas the (3-out, 4-in)-transition structure has the Ph-group inside, resulting in a more crowded transition structure for this last arrangement.





**FIGURE 8.** A selected example of high diastereoselection induced from the C3 position of the emerging  $\beta$ -lactam. Geometries and relative energies were calculated at the B3LYP/6-31G\* level.

### 5.3. Imines Having Chiral Components at the Imine Carbon

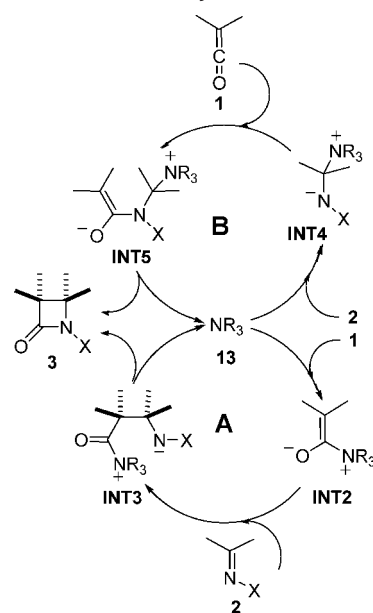
**Carbon.** There are several examples of highly diastereoselective Staudinger reactions in which the chiral induction stems from a chiral auxiliary at the imine carbon.<sup>40</sup> Imines derived from enantiopure aldehydes incorporating C–O or C–N bonds (namely, good  $\sigma$ -attractors) at the  $\alpha$ -position are specially efficient in inducing chirality in these reactions. For example, Staudinger reactions of imines **2t** derived from (*S*)-2-methoxypropanal lead to the corresponding *cis*- $\beta$ -lactams (*3S,4R*)-**3q** with high diastereoselectivity (Figure 8).<sup>38</sup> Analysis of the corresponding transition structures **TS<sub>2Mc</sub>** and **TS<sub>2Pc</sub>** shows<sup>41</sup> that in **TS<sub>2Pc</sub>** there is a collinear arrangement between the (3*S*) carbon atom and the C(*S*)–O bond with the Me-group placed outside of the emerging  $\beta$ -lactam, a group that is inside in the more energetic (3-out, 4-in)-saddle point **TS<sub>2Mc</sub>** (Figure 8). This constitutes an example of asymmetric torquoselectivity.<sup>26,27</sup>

## 6. Further Mechanistic Challenges: The Catalytic (and Asymmetric) Staudinger Reaction

The first synthesis of  $\beta$ -lactams from ketenes and imines catalyzed by chiral amines was described in 2000 by Lectka et al.<sup>11,42</sup> The catalytic process requires strongly electrophilic imines (imines bearing *N*-tosyl or alkoxy carbonyl groups) to produce satisfactory results. This fact is compatible with the reaction mechanism A depicted in Scheme 14.

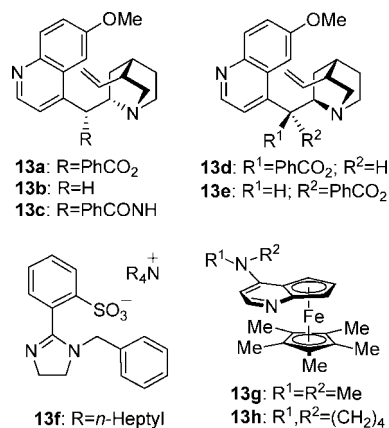
According to this mechanism, the catalyst adds to the  $sp^2$ -hybridized atom of the ketene to form zwitterion **INT2**. This enolate attacks the imine via a Mannich-like reaction to yield the intermediate **INT3** in which the chiral information

**SCHEME 14.** Possible Mechanisms for the Catalytic Staudinger Reaction in the Presence of Tertiary Amines

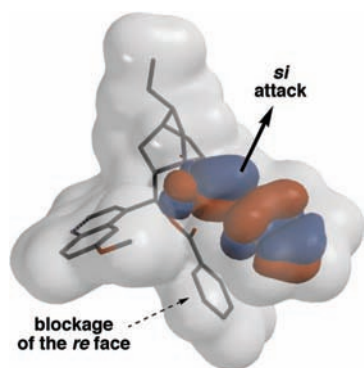


supplied by the catalyst **13** (Scheme 14) is transferred to the new C–C bond. Subsequent cyclization of zwitterion **INT3** leads to the formation of the reaction product **3** and to the regeneration of the catalyst. Good to excellent enantioselectivities have been obtained with the amines **13a–e** (Figure 9).

A systematic computational study on this mechanism has yet to be published. Lectka et al.<sup>43</sup> have explored computationally the formation of enolates **INT2** from phenyl ketene and the catalysts **13a–e** indicated in Figure 9. All these catalysts worked by blocking the *re* face of the enolate moiety (Figure 10), in which the HOMO of the enolate is closely related to the  $b_2(\pi)$  orbital of ketenes (Figure 1), These conclusions were in agreement with the experimental results. In addition, trapping experiments, DFT calculations, and IR measurements are consistent with the formation of intermediates of type **INT2**.<sup>9</sup>



**FIGURE 9.** Catalysts for the Staudinger reaction.



**FIGURE 10.** Shape of the intermediate **INT2** resulting from the interaction between catalyst **13e** and phenylketene, according to Lectka et al.<sup>43</sup> The enolate-like HOMO shows the bias for the *si*-attack.

Catalysts **13a–e** yield mainly or exclusively *cis*- $\beta$ -lactams, probably because of the formation of (*Z*)-enolates like those shown in Figure 10. Recently, the preferential formation of *trans*- $\beta$ -lactams using achiral catalysts of type **13f** (Figure 9) has been reported. Formation of (*E*)-enolates of type **INT2** (Scheme 14) have been postulated to explain this change in stereoselectivity.<sup>44</sup>

Fu et al.<sup>45</sup> have described the very efficient catalysts **13g,h** (Figure 9). Two mechanisms are operative with these catalysts depending on the imine. For *N*-Ts imines the cycle A in Scheme 14 is operative, while for *N*-Tf imines leading to *trans*- $\beta$ -lactams,<sup>46</sup> the mechanism of type B was proposed.<sup>45</sup> Mechanism B involves the imine instead of the ketene as the reagent being activated by the catalyst to form the intermediate **INT4**. The highly nucleophilic nitrogen atom of the resulting species attacks the *sp*-hybridized atom of the ketene to yield the enolate **INT5**. Finally, the [4-*exo-tet*] cyclization of **INT5** forms the corresponding *trans*- $\beta$ -lactam.

## 7. Conclusions and Outlook

The main features of the Staudinger reaction between ketenes and imines have been elucidated. The experimental evidence is compatible with a stepwise mechanism instead of a concerted [2 + 2] mechanism. The first step is the nucleophilic attack of the imine nitrogen on the central carbon atom of the ketene. The second step is the electrocyclic conrotatory ring closure to form the  $\beta$ -lactam ring. The stereochemistry of this second step is determined by torquoelectronic effects. When  $\alpha,\beta$ -unsaturated imines or vinyl ketenes are used, both [2 + 2] and [4 + 2] cycloadducts are obtained depending on the substitution patterns and the geometries of the competing conrotatory or disrotatory transition structures. The stereochemistry of the reaction appears to be related to the rotation about the N1–C4

bond of the zwitterionic intermediates. These results, together with the recent report describing the role of alternate isomerization pathways in the imine before reaction with the ketene, deserve future research.

The catalytic version of the reaction probably proceeds via stepwise mechanisms in which either the ketene or the imine can be activated by the addition of the catalyst. Both the synthetic potential of this reaction and the preliminary elegant experiments and calculations to elucidate its mechanism augur an exceptional future for these processes. These studies will keep alive the fruitful dialogue between theory and experiment witnessed by the Staudinger reaction over these first 100 years.

*The authors thank the Spanish Ministerio de Educación y Ciencia (Grants CTQ2007-67730-C02-01/BQU, CTQ2007-67528/BQU, and Consolider-Ingenio 2010, CSD2007-00006) for financial support and our co-workers for their invaluable and enthusiastic collaboration on this project over all these years.*

## BIOGRAPHICAL INFORMATION

**Fernando P. Cossío** studied chemistry at the Universidad de Zaragoza (Spain) and received his Ph.D. in 1986 at the University of the Basque Country (UPV/EHU, Spain, Prof. C. Palomo). After a postdoctoral stay at CNRS (Talence, France, Dr. J.-P. Picard), he joined the UPV/EHU as *Profesor Titular* in 1988 and *Catedrático* in 2002. In 1994, after a short stay at UCLA in the laboratories of Prof. K. N. Houk, he decided to combine theoretical and experimental organic chemistry to investigate the origins of selectivity in chemical reactions. His research interests include pericyclic reactions, C–C bond-forming reactions, and medicinal chemistry (design and chemical synthesis of inhibitors of integrins and epigenetic enzymes).

**Ana Arrieta** studied chemistry at the University of the Basque Country (Spain) and received her Ph.D. in 1986 (Prof. C. Palomo). She joined the University of the Basque Country (UPV/EHU) as *Profesor Titular* in 1991. Her current research interests focus on the mechanism of [2 + 1], [2 + 2], [3 + 2], and [4 + 2] thermal cycloadditions.

**Miguel A. Sierra** studied chemistry at the UCM (Madrid) and received his Ph.D. in 1987 (Honors). He was appointed *Profesor Ayudante* in 1987. After a postdoctoral stay at Colorado State University (Prof. Louis Hegedus), he was promoted to *Profesor Titular* in 1990 and *Catedrático* in 2005 (UCM). His research encompasses the development of new processes based on transition-metal complexes, the preparation of new bioorganometallic compounds, and the design and synthesis of new energetic materials. He is Member of the Board of the Spanish Chemical Society, the Secretariat of the Organic Chemistry Group of this Society, and Member of the Scientific Advisory Board of the Organization for the Prohibition of Chemical Weapons (OPCW).

## FOOTNOTES

\*To whom correspondence should be addressed. E-mail address: fp.cossio@ehu.es.

## REFERENCES

- (a) Staudinger, H. Über ketene. 4. Mitteilung: Reaktionen des diphenylketens. *Liebigs Ann. Chem.* **1907**, *40*, 1145–1148. (b) Staudinger, H.; Klever, H. W. Über ketene. 5. Mitteilung: Reaktionen des dimethylketens. *Liebigs Ann. Chem.* **1907**, *40*, 1149–1153.
- Tidwell, T. T. Hugo (Ugo) Schiff, Schiff bases, and a century of  $\beta$ -lactam synthesis. *Angew. Chem., Int. Ed.* **2008**, *47*, 1016–1020.
- Georg, G. I.; Ravikumar, V. T. Stereocontrolled ketene-imine cycloaddition reactions. In *The Organic Chemistry of  $\beta$ -Lactams*; Georg, G. I., Ed.; VCH Publishers: New York, 1992; pp 295–368.
- Chemistry and Biology of  $\beta$ -Lactam Antibiotics*; Morin, R. B., Gorman, M., Eds.; Academic Press: New York, 1982; pp 1–3.
- Alcaide, B.; Almendros, P.; Aragoncillo, C.  $\beta$ -Lactams: Versatile building blocks for the stereoselective synthesis of non- $\beta$ -lactam products. *Chem. Rev.* **2007**, *107*, 4437–4492.
- Palomo, C.; Aizpurua, J. M.; Ganboa, I.; Oiarbide, M. Asymmetric synthesis of  $\beta$ -lactams by Staudinger ketene-imine cycloaddition reaction. *Eur. J. Org. Chem.* **1999**, *322*, 3–3235.
- (a) Brady, W. T.; Shieh, C. H. Halogenated ketenes. 38. Cycloaddition of  $\alpha,\beta$ -unsaturated imines with ketenes to yield both  $\beta$ - and  $\delta$ -lactams. *J. Org. Chem.* **1983**, *48*, 2499–2502. (b) Moore, H. W.; Hughes, G.; Srinivasachar, K.; Fernandez, M.; Nguyen, N. V.; Schoon, D.; Tranne, A. Cycloadditions of cyanoketenes to cinnamylideneamines and benzylideneamines. Synthetic scope, stereochemistry and mechanism. *J. Org. Chem.* **1985**, *50*, 4231–4238.
- Bennett, D.; Okamoto, I.; Danheiser, R. L. Hetero [4 + 2] cycloadditions of (trialkylsilyl)vinylketenes. Synthesis of  $\alpha,\beta$ -unsaturated  $\delta$ -valerolactones and  $\beta$ -lactams. *Org. Lett.* **1999**, *1*, 641–644.
- Taggi, A. E.; Hafez, A. M.; Wack, H.; Young, B.; Ferraris, D.; Lectka, T. The development of the first catalyzed reaction of ketenes and imines: Catalytic asymmetric synthesis of  $\beta$ -lactams. *J. Am. Chem. Soc.* **2002**, *124*, 6626–6635.
- Hodous, B. L.; Fu, G. C. Enantioselective Staudinger synthesis of  $\beta$ -lactams catalyzed by a planar-chiral nucleophile. *J. Am. Chem. Soc.* **2002**, *124*, 1578–1579.
- France, S.; Weatherwax, A.; Taggi, A. E.; Lectka, T. Advances in the catalytic, asymmetric synthesis of  $\beta$ -lactams. *Acc. Chem. Res.* **2004**, *37*, 592–600.
- Cooper, R. G. D.; Daugherty, B. W.; Boyd, D. B. Chiral control of the Staudinger reaction. *Pure Appl. Chem.* **1987**, *59*, 485–492.
- Woodward, R. B.; Hoffmann, R. The conservation of orbital symmetry. *Angew. Chem., Int. Ed. Engl.* **1969**, *8*, 781–853.
- Zimmerman, H. E. The Möbius–Hückel concept in organic chemistry. Application to organic molecules and reactions. *Acc. Chem. Res.* **1971**, *4*, 272–280.
- (a) Xu, Z. F.; Fang, D. C.; Fu, X. Y. Ab initio studies on the mechanism of the cycloaddition reaction of fluoroketene with imines- substituent effects. *J. Mol. Struct. (Theochem)* **1994**, *305*, 191–196. (b) Fang, D.; Fu, X. An ab initio study on the mechanism of cycloaddition reaction of ketene with methyleneimine: A new reaction scheme. *Int. J. Quantum Chem.* **1992**, *43*, 669–676.
- Cossio, F. P.; Ugalde, J. M.; Lopez, X.; Lecea, B.; Palomo, C. A semiempirical theoretical study on the formation of  $\beta$ -lactams from ketenes and imines. *J. Am. Chem. Soc.* **1993**, *115*, 995–1004.
- Sordo, J. A.; González, J.; Sordo, T. L. An ab initio study on the mechanism of the ketene-imine cycloaddition reaction. *J. Am. Chem. Soc.* **1992**, *114*, 6249–6251.
- Assfeld, X.; Ruiz-López, M. F.; González, J.; López, R.; Sordo, J. A.; Sordo, T. L. Theoretical analysis of the role of the solvent on the reaction mechanisms. One step versus 2 step ketene–imine cycloaddition. *J. Comput. Chem.* **1994**, *15*, 479–487.
- (a) Decazes, J. M.; Luche, J. L.; Kagan, H. B.; Parthasarathy, R.; Ohrt, J. T. Cycloaddition of ketenes with Schiff bases V. Structure and stereochemistry of adducts formed in liquid  $\text{SO}_2$ . *Tetrahedron Lett.* **1972**, *13*, 3633–3636. (b) Bellus, D. Incorporation of sulfur dioxide into the products of reaction of Schiff bases with halo- or alkylthioketenes in liquid  $\text{SO}_2$ . Preliminary communication. *Helv. Chim. Acta* **1975**, *58*, 2509–2511.
- Lecea, B.; Arrastia, I.; Arrieta, A.; Roa, G.; Lopez, X.; Arriortua, M. I.; Ugalde, J. M.; Cossio, F. P. Solvent and substituted effects in the periselectivity of the Staudinger reaction between ketenes and  $\alpha,\beta$ -unsaturated imines. A theoretical and experimental study. *J. Org. Chem.* **1996**, *61*, 3070–3079.
- Pacansky, J.; Chang, J. S.; Brown, D. W.; Schwarz, W. Observation of zwitterions in the thermal reaction of ketenes with carbon–nitrogen double bonds. *J. Org. Chem.* **1982**, *47*, 2233–2234.
- Quiao, G. H.; Andraos, J.; Wentrup, C. Reactivity of ketene in matrices. Direct observation of ketene–pyridine ylides. *J. Am. Chem. Soc.* **1996**, *118*, 5634–5638.
- (a) Martelli, G.; Spunta, G.; Panunzio, M. Microwave-assisted solvent-free organic reactions: Synthesis of  $\beta$ -lactams from 1,3-azadienes. *Tetrahedron Lett.* **1998**, *39*, 6257–6260. (b) Panunzio, M.; Bacchi, S.; Campana, E.; Fiume, L.; Vicennati, P. Reversal of stereochemistry in a two-step Staudinger reaction by changing the backbone protecting group. Synthesis of *NH*-trans-3-benzoyloxy-4-aryl-azetidiones. *Tetrahedron Lett.* **1999**, *40*, 8495–8498. (c) Bandini, E.; Favi, G.; Martelli, G.; Panunzio, M.; Piersanti, G. A trans-stereoselective synthesis of 3-halo-4-alkyl(aryl)-NH-azetidin-2-ones. *Org. Lett.* **2000**, *2*, 1077–1079.
- (a) Liang, Y.; Jiao, L.; Zhang, S.; Xu, J. Microwave- and photoirradiation-induced Staudinger reactions of cyclic imines and ketenes generated from  $\alpha$ -diazoketones. A further investigation into the stereochemical process. *J. Org. Chem.* **2005**, *70*, 334–337. (b) Jiao, L.; Liang, Y.; Xu, J. Origin of the relative stereoselectivity of the  $\beta$ -lactam formation in the Staudinger reaction. *J. Am. Chem. Soc.* **2006**, *128*, 6060–6069.
- Jefford, C. W.; Bernardelli, G.; Wang, Y.; Spellmeyer, D. C.; Buda, A.; Houk, K. N. Torquoselectivity in the electrocyclic conversion of benzocyclobutanes to ortho-xylenes. *J. Am. Chem. Soc.* **1992**, *114*, 1157–1165.
- Dolbier, W. R., Jr.; Korionak, H.; Houk, K. N.; Sheu, C. Electronic control of stereoselectivities of electrocyclic reactions of cyclobutenes: A triumph of theory in the prediction of organic reactions. *Acc. Chem. Res.* **1996**, *29*, 471–477.
- Niwayama, S.; Kallel, E. A.; Spellmeyer, D. C.; Sheu, C.; Houk, K. N. Substituent effects on rates and stereoselectivities of conrotatory electrocyclic reactions of cyclobutenes. A theoretical study. *J. Org. Chem.* **1996**, *61*, 2813–2825.
- López, R.; Sordo, T. L.; Sordo, J. A.; González, J. Torquoelectronic effect in the control of the stereoselectivity of ketene-imine cycloaddition reactions. *J. Org. Chem.* **1993**, *58*, 7036–7037.
- Arrastia, I.; Arrieta, A.; Ugalde, J. M.; Cossio, F. P.; Lecea, B. Theoretical and experimental studies on the periselectivity of the cycloaddition reaction between activated ketenes and conjugated imines. *Tetrahedron Lett.* **1994**, *42*, 7825–7828.
- (a) Abbiati, G.; Rossi, E. [2 + 2] Cycloaddition reactions of 1-benzyl-2,4-diphenyl-1,3-diazabuta-1,3-diene with chiral ketenes. *Tetrahedron* **2001**, *57*, 7205–7212. (b) Barbaro, G.; Battaglia, A.; Giorgianni, P. Periselectivity in cycloadditions to vinylmethylketene and structurally related vinylketeneimines. *J. Org. Chem.* **1987**, *52*, 3289–3296.
- Dumas, S.; Hegedus, L. S. Electronic effects on the stereochemical outcome of the photochemical reaction of chromium carbene complexes with imines to form  $\beta$ -lactams. *J. Org. Chem.* **1994**, *59*, 4967–4971.
- Li, B.; Wang, Y.; Du, D.-M.; Xu, J. Notable and obvious ketene substituent-dependent effect of temperature on the stereoselectivity in the Staudinger reaction. *J. Org. Chem.* **2007**, *72*, 990–997.
- Arrieta, A.; Ugalde, J. M.; Cossio, F. P.; Lecea, B. Role of the isomerization pathways in the Staudinger reaction. A theoretical study on the interaction between activated ketenes and imines. *Tetrahedron Lett.* **1994**, *35*, 4465–4468.
- Banik, B. K.; Becker, F. F. Unprecedented stereoselectivity in the Staudinger reaction with polycyclic aromatic imines. *Tetrahedron Lett.* **2000**, *41*, 6551–6554.
- Banik, B.; Lecea, B.; Arrieta, A.; de Cózar, A.; Cossio, F. P. On the stereodivergent behavior observed in the Staudinger reaction between methoxyketene and (E)-N-benzylidenearyl amines. *Angew. Chem., Int. Ed.* **2007**, *46*, 3028–3032.
- Podlech et al also proposed a possible imine isomerization in the photochemically induced Staudinger reaction. See, for example: (a) Linder, M. R.; Frey, W. U.; Podlech, J. Diazoketenes as precursors in  $\beta$ -lactam synthesis. New insights into the mechanism of the photochemically induced Staudinger reaction. *J. Chem. Soc., Perkin Trans. 1* **2001**, *256*, 6–2577. (b) Linder, M. R.; Podlech, J. Synthesis of  $\beta$ -lactams from diazoketones and imines: The use of microwave irradiation. *Org. Lett.* **2001**, *3*(12), 1849–1851.
- Martín-Zamora, E.; Ferrere, A.; Llera, J. M.; Muñoz, J. M.; Pappalardo, R. R.; Fernández, R.; Lassaletta, J. M. Studies on stereoselective [2 + 2] cycloadditions between N,N-dialkylhydrazones and ketenes. *Chem.—Eur. J.* **2004**, *10*, 6111–6129.
- Evans, D. A.; Sjogren, E. The asymmetric synthesis of  $\beta$ -lactam antibiotics - 1. Application of chiral oxazolidones in the Staudinger reaction. *Tetrahedron Lett.* **1985**, *26*, 3783–3786.
- Cossio, F. P.; Arrieta, A.; Lecea, B.; Ugalde, J. M. Chiral control in the Staudinger reaction between ketenes and imines. A theoretical SCF-MO study on asymmetric torquoselectivity. *J. Am. Chem. Soc.* **1994**, *116*, 2085–2093.
- (a) Palomo, C.; Cossio, F. P.; Cuevas, C.; Lecea, B.; Mielgo, A.; Román, P.; Luque, A.; Martínez-Ripoll, M. Contribution to the development of new substitution patterns of optically active  $\beta$ -lactams: Synthesis of homochiral 4-(1-aminoalkyl)azetidion-2-ones from *N*-(*tert*-butoxycarbonyl)  $\alpha$ -amino aldehyde-derived imines via asymmetric Staudinger reaction. *J. Am. Chem. Soc.* **1992**, *114*, 9360–9369, and the pertinent references therein. (b) Palomo, C.; Cossio, F. P.; Ontoria, J. M.; Odriozola, J. M.

- Preparation of chiral 3-unsubstituted  $\beta$ -lactams from 3-hydroxy- $\beta$ -lactams by using the alkoxyketene-imine cycloaddition reaction as an approach to the azetidinone ring: A formal synthesis of the carbapenem antibiotic (+)-PS-5. *Tetrahedron Lett.* **1991**, *32*, 3105–3108.
- 41 Arrieta, A.; Cossio, F. P.; Lecea, B. New insights on the origins of the stereocontrol in the Staudinger reaction: [2 + 2] cycloaddition between ketenes and *N*-silylimines. *J. Org. Chem.* **2000**, *65*, 8458–8464.
- 42 Taggi, A. E.; Hafez, A. M.; Wack, H.; Young, B.; Drury, W. J., III; Lectka, T. Catalytic, asymmetric synthesis of  $\beta$ -lactams. *J. Am. Chem. Soc.* **2000**, *122*, 7831–7832.
- 43 Taggi, A. E.; Hafez, A. M.; Dudding, T.; Lectka, T. Molecular mechanics calculations as predictors of enantioselectivity for chiral nucleophile catalyzed reactions. *Tetrahedron* **2002**, *58*, 8351–8356.
- 44 Weatherwax, A.; Abraham, C. J.; Lectka, T. An anionic nucleophilic catalyst system for the diastereoselective synthesis of *trans*- $\beta$ -lactams. *Org. Lett.* **2005**, *7*, 3461–3463.
- 45 Lee, E. C.; Hodous, B. L.; Bergin, E.; Shih, C.; Fu, G. C. Catalytic asymmetric Staudinger reactions to form  $\beta$ -lactams: An unanticipated dependence of diastereoselectivity on the choice of the nitrogen substituent. *J. Am. Chem. Soc.* **2005**, *127*, 11586–11587.
- 46 For another type of catalytic activation of the imine, see: France, S.; Shah, M. H.; Weatherwax, A.; Wack, H.; Roth, J. P.; Lectka, T. Bifunctional Lewis acid-nucleophile-based asymmetric catalysis: Mechanistic evidence for imine activation working in tandem with chiral enolate formation in the synthesis of  $\beta$ -lactams. *J. Am. Chem. Soc.* **2005**, *127*, 1206–1215.